



Femtosecond Solid-State Lasers



Ti:Sapphire Femtosecond Lasers TiF

- Tuning range: 710-970 nm
- Pulse duration down to 20 fs
- Small footprint
- Output power up to 1.5 W
- Optional thermostabilized main breadboard
- Motorized USB wavelength tuning
- Electromagnetic starter
- Kit version available



TiF-50M femtosecond solid-state Ti:S laser

Product overview

The TiF laser series, being one of our first products, has been upgraded over the years to match the increasing demand for stability and hands-free operation from scientists all over the world. The laser comprises a selected Ti:Sapphire crystal, compact or long resonator design, electronic control of emitted wavelength (by controlling both wavelength tuning slit and one of the prisms), electronic starter unit for easy maintenance of fs regime, and an additional mirror set if broad wavelength tuning is required (see tuning curves for the laser).

The two main models are TiF and TiF-M, the only difference being the size of the unit. The traditional TiF variant is more suitable when there is no strict space requirement and some upgrades and customization of the laser are planned after the purchase. We also recommend this version for education purposes. The new TiF-M unit has compact design and yet provides stable generation.

The laser is shipped fully aligned and tested for the desired specification and at normal transportation conditions the laser can be aligned by the customer following the steps described and illustrated in the laser manual. Once the laser has been aligned, little to no day-to-day maintenance is required. The amount of maintenance greatly depends on room temperature stability over time. To improve stability in poor room conditions we offer a thermostabilized main breadboard option for the TiF-M model.

As for the cooling issue, the crystal can be cooled by moderate tap water flow or no cooling at all may be necessary with 3W pump. However, we strongly recommend using a chiller for greater stability, especially with the thermostabilized main breadboard.

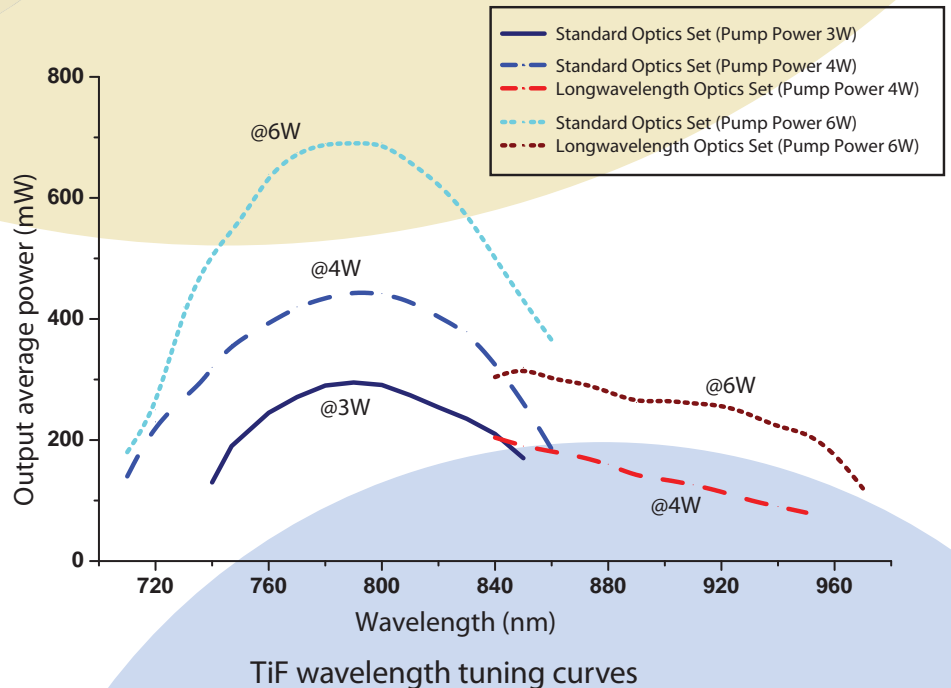
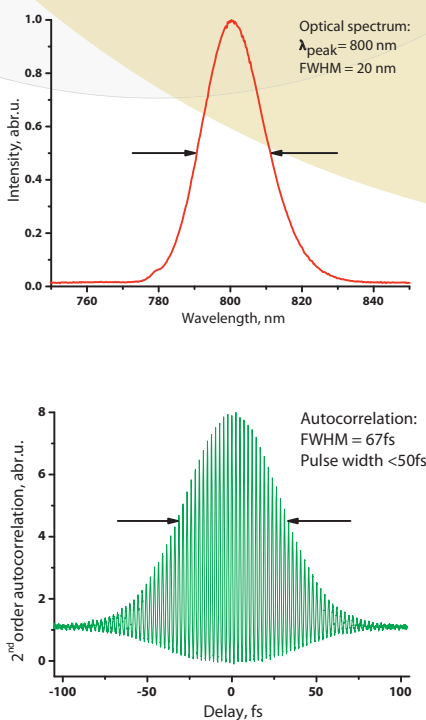

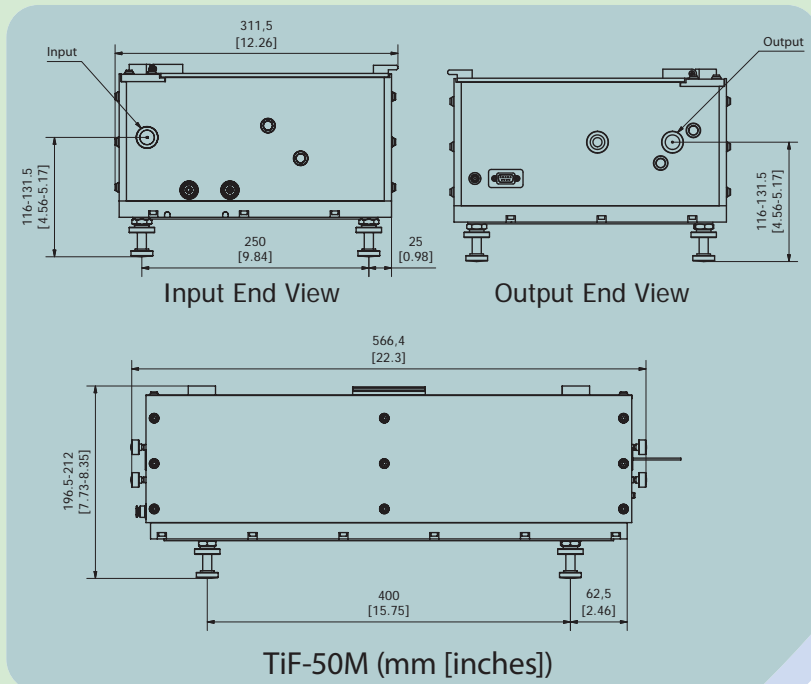
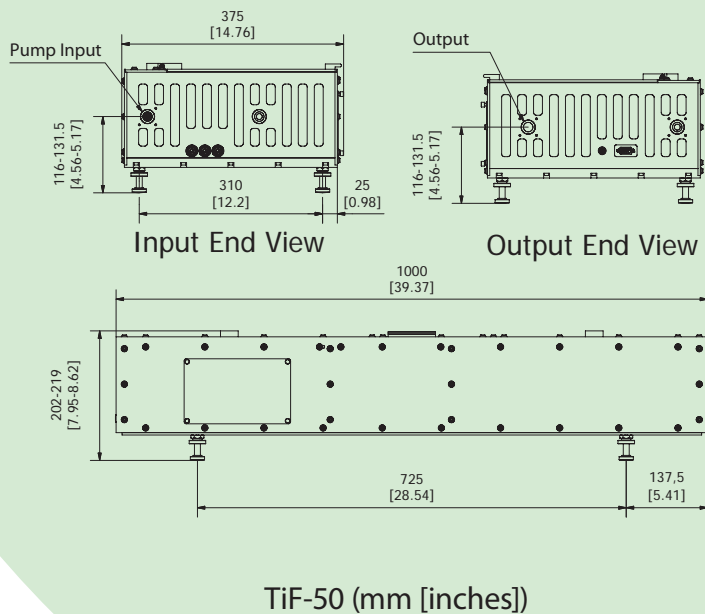

TiF technical specifications

	TiF-20	TiF-50/TiF-50M	TiF-100/TiF-100M
Pulse duration, fs	<20***	<50	<100
Tuning range, nm	780-840	740-920* 710-970**	
Output power at 800 nm, mW	150-250*	300-900*	300-1500*
Pump power, W	3-5	3-7	3-10
Repetition rate, MHz	80 (75 to 125 MHz available upon request)		
Output stability, typical	<1% rms		
Spatial mode	TEM ₀₀		
Polarization, linear	horizontal		
Beam divergence, mrad	<2		
Electronic starter	yes		
USB wavelength tuning	yes		
Water-cooled thermostabi- lized breadboard	optional		
Dimensions, mm	1000x360x200	TiF – 1000x360x200 / TiF-M – 566x312x197	

* - depends on pump power. Please see tuning curves for exact values. Two mirror sets (included in the package) are required to cover the whole tuning range.

** - at pump power >5W.

*** - with external group velocity dispersion compensation.

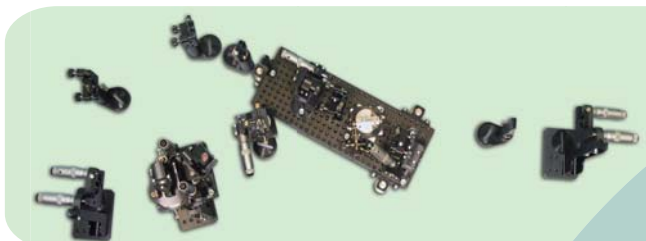

Ti:S and Cr:F kits are available.
Please contact us for details.