



Components



Third Harmonic Generator ATsG

- High conversion efficiency
- Small walk-off angle
- Low beam divergence
- No heating



Third harmonic generator ATsG

Product overview

Third harmonic generators ATsG800 and ATsG800-C are developed for producing coherent radiation at doubling and tripling frequency for TiSa femtosecond oscillator and amplifier, respectively. The input wavelength range is supposed to be from 750 to 900 nm. Principles of work are based on second and sum-frequency generation technique and provide stable radiation with good beam quality and small pulse broadening in fs scale.

ATsG technical specifications

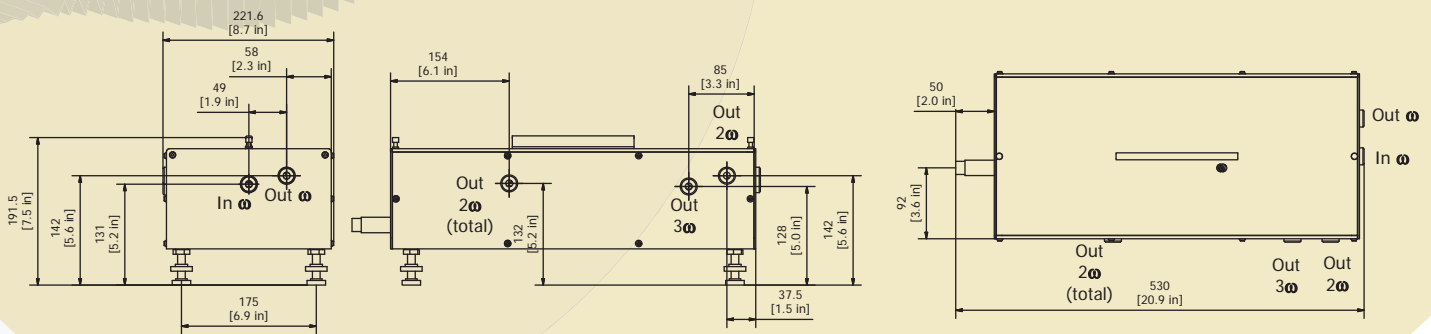

	ATsG800		ATsG800-C	
	SH output	TH output	SH output	TH output
Input wavelength, nm	710 - 960*	750-900*	750 - 900*	
Output wavelength range, nm	355 - 480	250-300	375 - 450	250-300
Input pulse width, fs	> 20			
Input polarization	linear-horizontal			
Input average power, mW	400-1000			
Input energy, mJ			1-2	
Conversion efficiency	20-40%**	3-8%**	30-45%**	3-10%**
Temporal broadening, fs	< 100	< 200	< 100	< 200
Output polarization	linear-vertical	linear-horizontal	linear-vertical	linear-horizontal
Dimensions, mm	480x222x192			

* - the wavelength range from 690 to 1000 nm is also available with two sets of optics

** - depends on wavelength, input intensity and pulse duration



AMG-1000C (1028 nm version) technical specs

	AMG-1000C		
	SH output	TH output	FH output
Input wavelength, nm	1028		
Input pulse width, fs	300		
Output wavelength, nm	514	343	257
Input polarization	linear-vertical		
Input energy, μ J	100-200		
Conversion efficiency	>50%	>30%	>20%
Temporal broadening, fs	<300	<350	<400
Output polarization	linear-horizontal	linear-vertical	linear-vertical
Dimensions, mm	380x220x180		