



Components



Faraday Optical Isolators

- Peak isolation >38 dB
- Transmission (1064nm, 800nm) >90%
- Broadband isolators
- Tunable isolators

Application:

- Feedback elimination
- Amplifier design

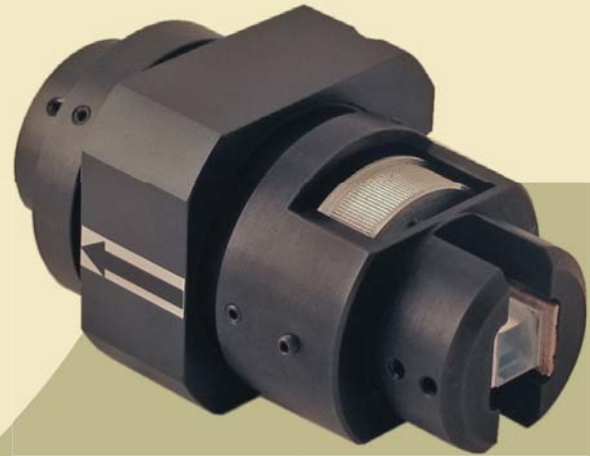

Tunable Faraday optical isolator for 730-860 nm

Product overview

A Faraday Isolator (FI) is a nonreciprocal optical device which transmits the linearly polarized light in one direction and deflects the backward beam. It usually consists of a Faraday Rotator and two polarizers. The Faraday Rotator is made of magneto-optical active material which is placed into the permanent magnet system (Nd-Fe-B). Three types of the magneto-optical active materials are available: Terbium-doped glass, Terbium-Gallium-Garnet (TGG) crystals or Yttrium-Iron-Garnet (YIG) crystals.

The FI protects a laser by attenuating the reflected and backscattered light by several orders of magnitude (10^4 to 10^6). It is also used when some devices have extreme sensitivity to optical feedback which can cause intensity instabilities, frequency pulling and other undesirable effects.

We offer the following models:

Highly transparent (HT) single stage isolators. Isolation 38-44 dB, wavelength 500-1250 nm (fixed), bandwidth - 30 nm. Clear aperture 3-16 mm. Transmission >90%.

Broadband isolators. Isolation >38 dB. Center wavelength - 800 nm (other designs are also available on request). Bandwidth - 200 nm. Clear aperture is 3-12 mm. HT and SE modifications are also available.

Tunable isolators. Peak isolation 38-42 dB. Central wavelength - 780 nm. Tuning range from 700 to 860 nm. Other wavelengths available upon request. Simple and convenient operation.

Narrowband adjustable isolators. Isolation 38-44 dB. Center wavelength - 800 nm. Tuning range from 770 - 830 nm. Other wavelengths available upon request.

Single stage isolators with side exit (SE). Isolation 38-44 dB, wavelength from 500 to 1250 nm (fixed), bandwidth - 30 nm. Clear aperture 3-16 mm. Transmission ~85%.

Double stage isolators. Isolation >60 dB. Wavelength is 800 - 1150 nm (fixed). Bandwidth - 30 nm. Clear aperture 3-12 mm.

Isolators for IR optical range. Isolation - 30 dB. Wavelength 1.25 - 3.39 μm (please request, as there are certain restrictions in this range).

Custom wavelengths, apertures are available. Feel free to enquire us at the e-mail below.

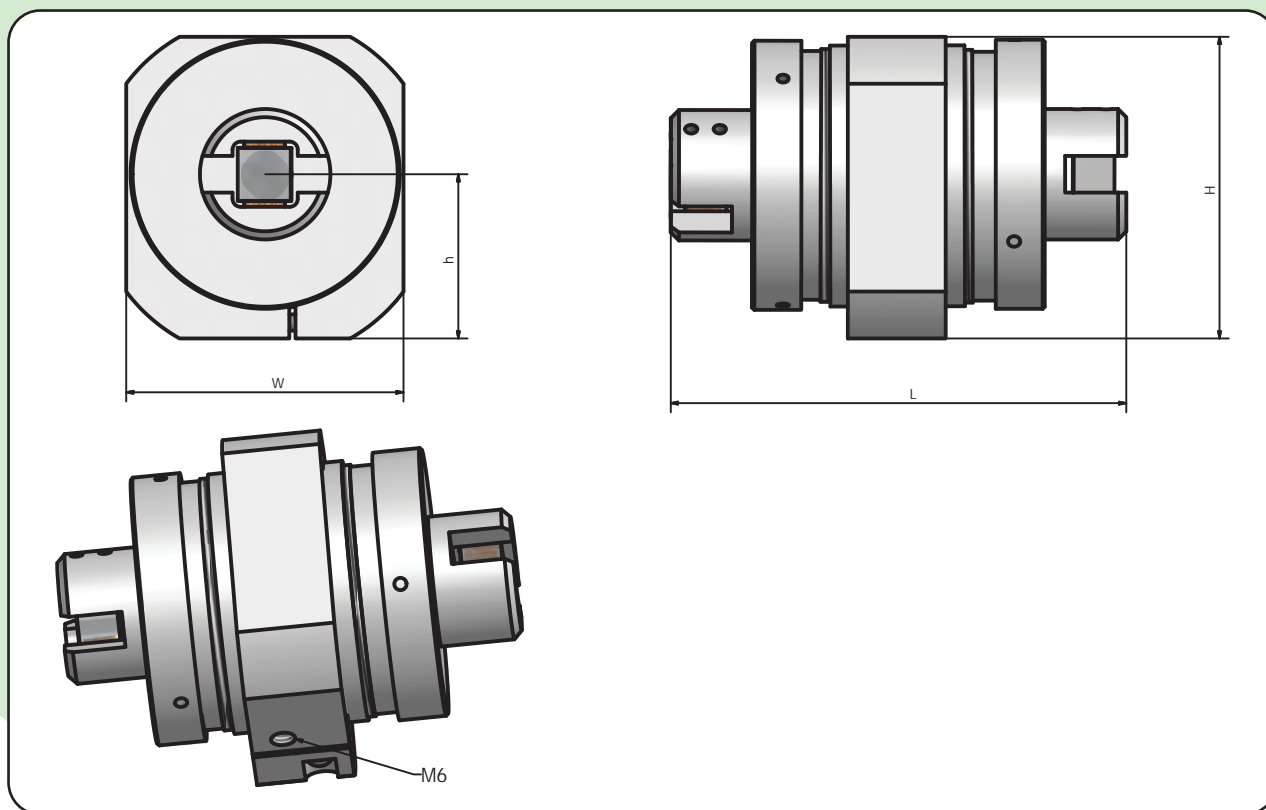

Isolators technical specifications

Wave-length, nm	Clear aper-ture, mm	Rod material	Dimensions, mm, (LxWxH)beam height	Peak iso-lation, dB	Transmis-sion, %	Model		
3390	5	YIG	(27x24x24)12	28-30	>75	5AFI30-3390Y		
1250		TGG	(84x76x82)43	>38	>90	5AFI38-1250C		
1064	5	TGG	(92x59x65)37,5	>38	>90	5AFI38-1064C		
		Glass				5AFI38-1064G		
	8	TGG	(97x68x74)40			8AFI38-1064C		
		Glass				8AFI38-1064G		
	10	TGG	(104x68x74)40			10AFI38-1064C		
	12					(134x50x50)25	12AFI38-1064C	
						12AFI38-1064C-LP		
800	5	TGG	(79x48x54)30	>38	>90	5AFI38-800C		
		Glass				5AFI38-800G		
	8	TGG	(97x68x74)40			8AFI38-800C		
		Glass				8AFI38-800G		
Tunable, 700-860	5	TGG	(103x48x54)30	>38*	>90*	5AFI38T-780C		
		Glass				5AFI38T-780G		
Broadband, 730-860		TGG	(84x48x54)30			>38**	>90**	5AFI38B-800C
		Glass						5AFI38B-800G

* - at peak (tunable).

** - at 800 nm. Please see transmission curves for full transmission and isolation info.