



Diagnostics



Cross-Correlator COMET

- High dynamic range
- High temporal range
- High sensitive photodetector
- USB compatible

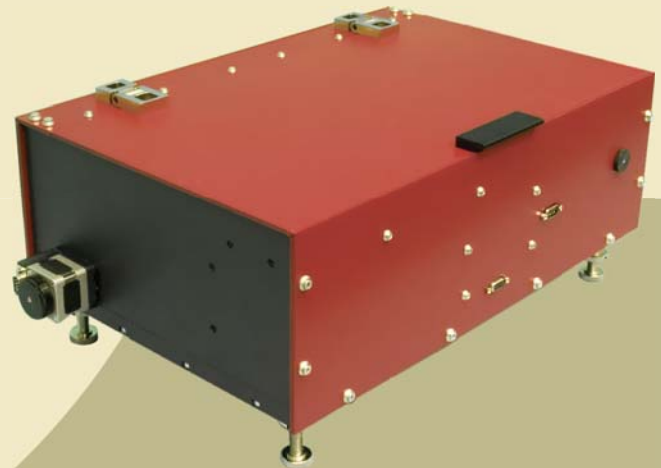

Cross-correlator COMET

Product overview

The new third order cross-correlator has been specifically developed for measuring a wide array of output parameters from ultrafast laser systems including: contrast ratio of laser pulses, determining pulse pedestal, pre- and post-pulses, and amplified spontaneous emission in femtosecond systems. It also provides information about the third-order cross-correlation function of pulse intensity on a femtosecond scale and can be used for alignment of high power femtosecond lasers.

Cross-correlator includes opto-mechanical assembly and electronics with USB interface. System is easy to operate and includes a full set of user friendly software tools for data collection and analysis.

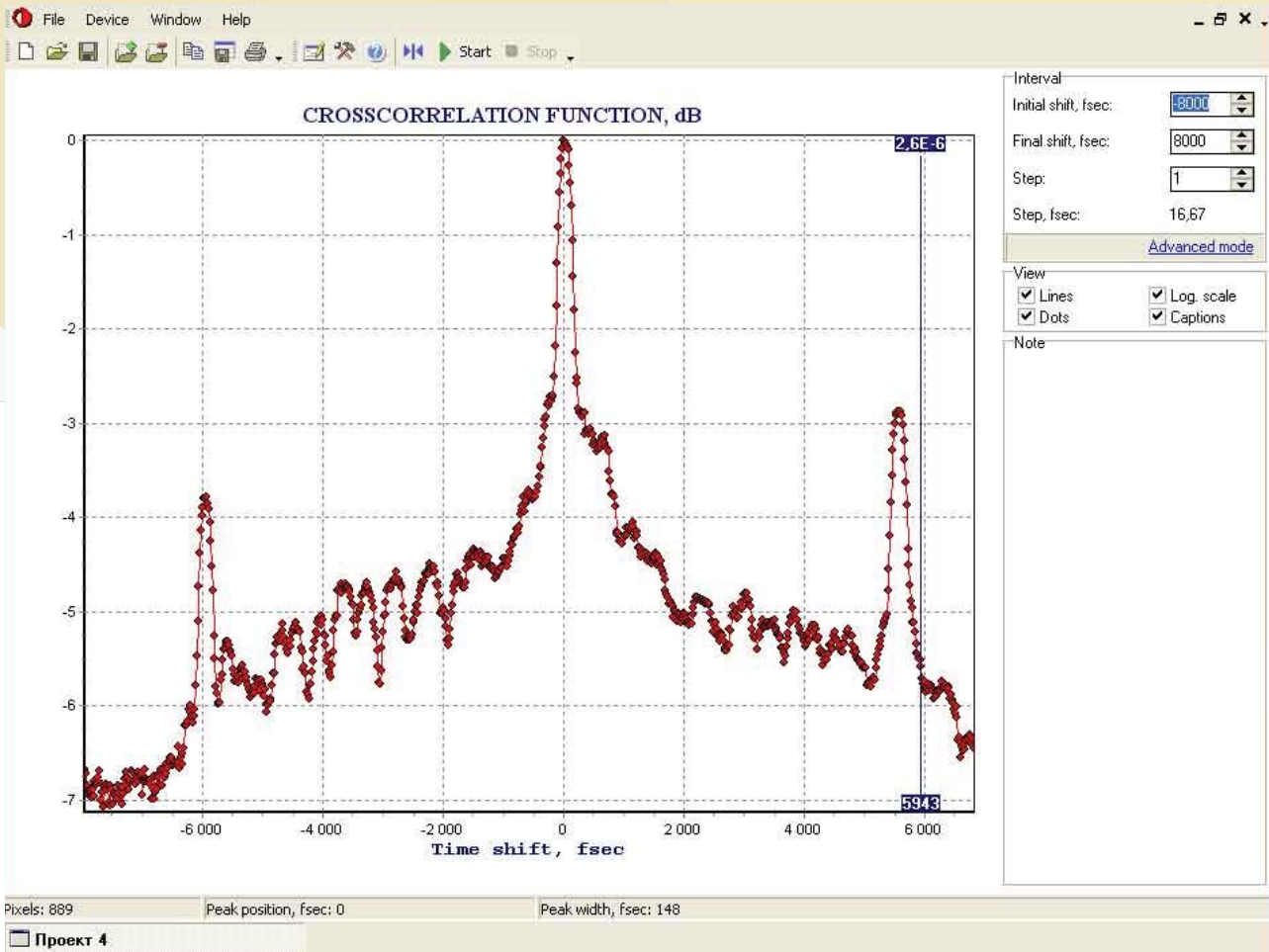

Software screenshot

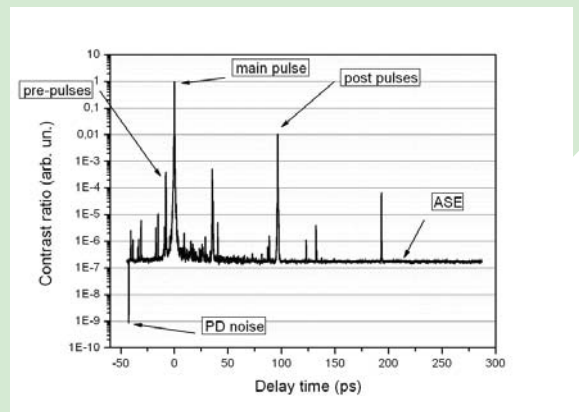
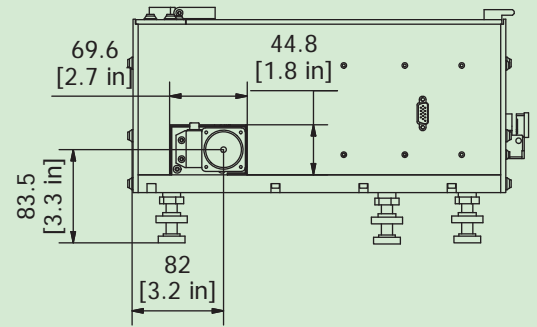
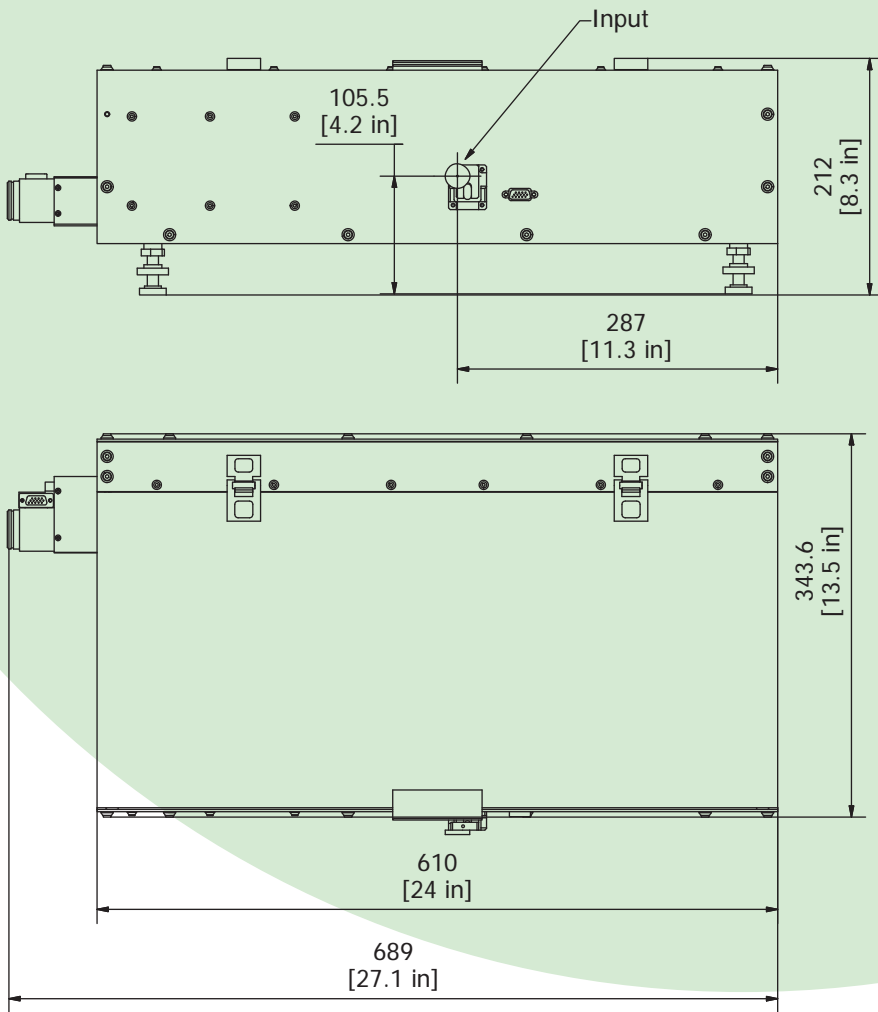

Contrast/delay graph

## COMET technical specifications

	COMET
Wavelength, nm	700-1500*
Dynamic range	>10 <sup>9**</sup>
Temporal range, ps	950
Input radiation energy (40-50 fs pulse), μJ	>80
Pulse duration, fs	> 20
Repetition rate, kHz	< 3***
Input polarization, linear	horizontal
Resolution, fs	100
Electric power	220 / 110 V AC; 50/60 Hz +-10%
Dimensions, mm	Optical unit 690 x 345 x 210 Control unit 250 x 180 x 90

\* - according to customer's request

\*\* - > 10<sup>10</sup> dynamic range is possible for version with PMT.

\*\*\* - < 8 kHz repetition rate is available for version with PMT.